

DX1001-M

The DX modular housing arrangement offers a flexible and space conscious solution to integrating our innovative DXO Cartridge to both new and existing systems. We provide up to 12 cartridges as a single unit in a compact and easily maintainable layout.

The unit can be supplied with a number of standard options to provide an effective conditioning and monitoring package to suit the majority of systems. The flexibility of the unit allows tailoring to a customer's specific requirements.



DXO Cartridge

Dirt capacity:	1955 g, 0.1 micron
Water absorption, free and bound:	M 2600ml
Material insert:	Cellulose, Polypropylene



Technical Specification

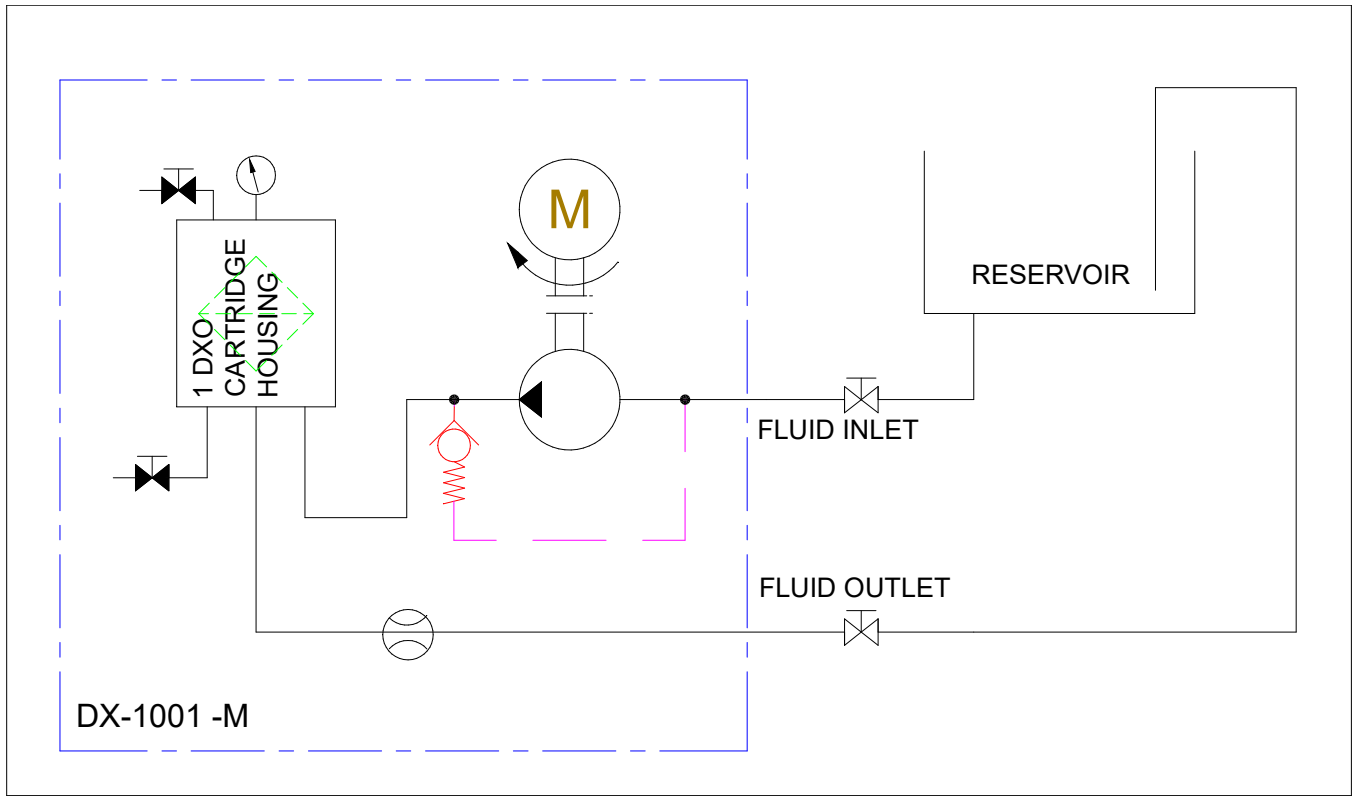

DX1001-T

AC Power	0,25KW , 110, 220-480 VAC, 50/60Hz
Pump Connection Ports	3/8" BSP In & Out
Sight Glass	Yes
Hydraulic Oil Volume Capacity	3000 Litres @ 32cSt
Typical Flow	1 Lpm ISOVG32 @ 20°C
Micron Rating	0,1 Micron
Weight[kgs]	45
Measure [mm]	H 945 x D 558 x L567
Material	SS316
DXO Cartridge	x 1



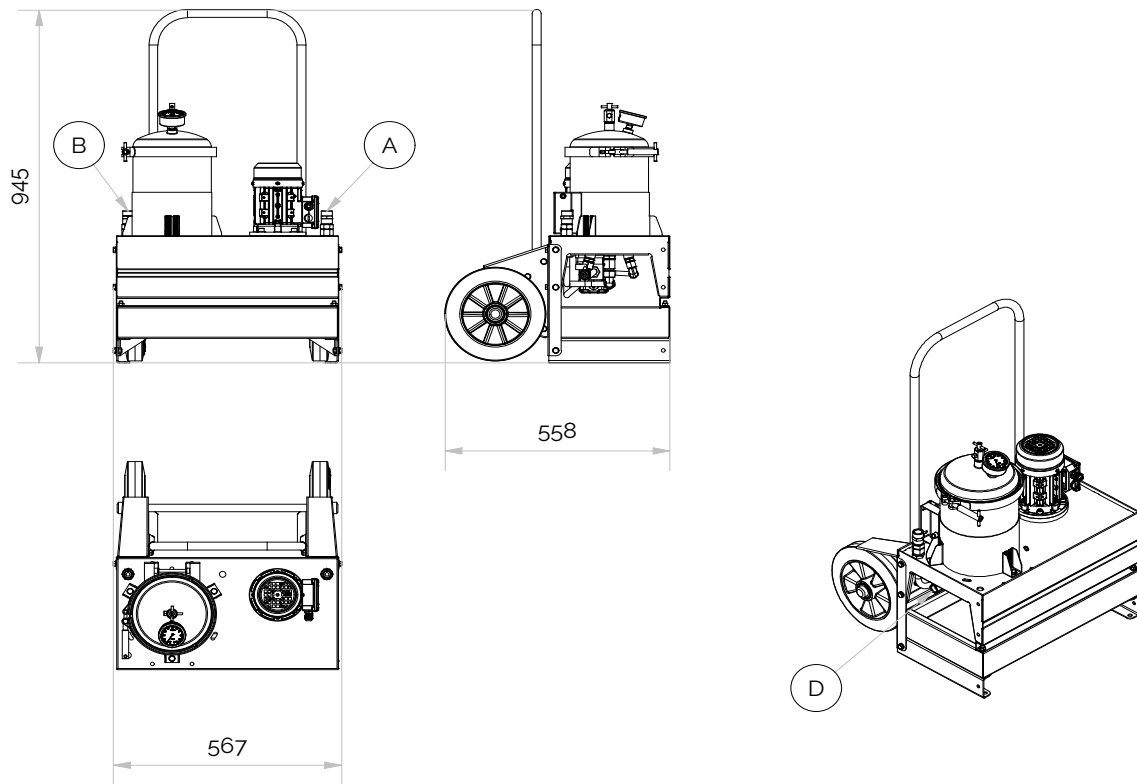

HIGHLY EFFICIENT OIL CLEANER
COMPACT AND MODULE BASED

- REMOVES PARTICLES
- MITIGATES VARNISH
- ABSORBS WATER

MAX. 7 BAR
CLEANS FROM OIL RESERVOIR AND BACK

© 2019 Delta-Xero All Rights Reserved

PARTS LIST

ITEM	QTY	PART NUMBER	DESCRIPTION	MATERIAL
A	1	INLET	INLET G1/2"	SS316L
B	1	OUTLET	OUTLET G1/2"	SS316L
C	1	DX1001M	DX1001M SINGLE MOBILE OIL CLEANER, 220-240V	SS316L
D	1	DRAIN	DRAIN G1/2"	SS316L

Designed by DX	Checked by	Approved by	Date	Date 17.12.2019
-------------------	------------	-------------	------	--------------------

 <p>DELTA-XERO THE FUTURE IS SYSTEM RELIABILITY</p>	DX1001M SINGLE MOBILE OIL CLEANER		
	DX1001M SINGLE MOBILE OIL CLEANER	Edition A2019	Sheet 1 / 3

